



XIM LED Modules

with Corrected Cold Phosphor Technology®
Standard Series

Xicato designs and delivers one of the broadest portfolio spot and linear light sources and electronics that enable architects, designers and building managers to create beautiful, smart spaces in which people love to live and work. With thousands of installations around the globe, Xicato continues to be a leading supplier of high quality lighting solutions. Xicato is defining the future of intelligent light sources by integrating electronics, software and connectivity. Founded in 2007, Xicato's headquarters is based in Silicon Valley and the company has offices in China, Europe and the US.

About this Document

This datasheet is just one of many documents and tools available from Xicato to assist lighting designers, specifiers, and luminaire manufacturers in understanding and using Xicato products. These include:

Accessory Selection Tools (Heatsinks, Optics, Drivers)

Xicato has a searchable database of driver, reflectors, and heat sinks that have been evaluated by Xicato and can be integrated with Xicato's light sources. Users can search and filter on a wide range of parameters to match the desired solution for their application. Contact your sales representative or technical application representative for more details.

CAD Files & Drawings

2D and 3D files are available upon request from orders@xicato.com

Application & Technical Notes

Xicato has an extensive list of application notes for proper handling and usage of the modules.



Table of Contents

XIM LED Modules with Corrected Cold Phosphor Technology®	1
Standard Series	1
About this Document	2
Table of Contents	3
General Description	4
Xicato Corrected Cold Phosphor Portfolio	5
Ordering Guide	6
Mechanical Characteristics	9
Electrical & Dimming Characteristics	12
Wireless Specifications & Compliance	13
Software & Firmware Features	14
Internal Sensor Data Collection & Storage	15
XIM Warranty	15
Initial Color Consistency – Details	16
Color Metrics: Standard Series	16
IES LM-80	19
Performance Characteristics	21
Basic Handling and Assembly	23
Regulatory Information	24
Luminaire Specification: Recommended LED Module	27

General Description

XIM

The Xicato Intelligent Module (XIM) is a compact, integrated LED lighting module designed to fit a wide variety of downlight and spot fixtures, and to simplify the design and assembly of controllable LED luminaires. The XIM includes:

- LED emitting core
- Drive electronics – constant voltage to constant current (dimmable)
- Microprocessor with firmware and static random access memory (SRAM)
- Internal sensors that detect intensity, LED and PCB temperature, power, and other operating parameters
- Bluetooth Smart wireless transceiver (XIM Gen4 only)

The extremely high quality, integrated XIM driver dims more smoothly and deeply than high-end standalone LED drivers. Combined with Xicato's industry leading color quality, consistency and application-optimized light spectra, XIM provides simply the most beautiful lit effect.

Integration makes the XIM more affordable to implement and enables smaller downlight or spotlight fixtures.

Xicato is the only light source provider to give a long term warranty on both output and color consistency, creating a strong case for lowest total cost of ownership and smallest ecological footprint, while insuring consistent lighting design quality for the life of the installation.

Over its broad dimming range, XIM exceeds the highest international standards for avoiding health effects related to flicker - it is the only LED solution to achieve this.

XIM Generation 4 (XIM GEN4)

To the standard XIM, XIM Gen4 adds Bluetooth wireless connectivity and the distributed intelligence required to respond to all types of sensors, switches, and mobile app commands. XIM Gen4 is a control system, a beacon, and an intelligent IoT (Internet of Things) node that fundamentally changes the economics of lighting control, smart spaces and the lighting industry. XIM Gen4 dramatically simplifies and cost reduces the planning, installation, provisioning, control and management of controlled lighting, while enabling new location-based information services.

XIM Gen4 is about more than Lighting. XIM Gen4 can advertise Apple iBeacons, providing wayfinding and other location-based information about such things as museum exhibits, retail merchandise, or restaurant menus.

XIM Gen4 is part of a total ecosystem with compatible software, motion, lux, temperature, humidity and vibration sensors, switches, and gateways. Built on the ubiquitous Bluetooth standard already in billions of smartphones and tablets, Xicato has opened its software interfaces (APIs) to enable third-party developers to write their own apps, expanding opportunities for OEMs, lighting designers, M&Es, and end users.

Standard Series

Xicato Standard Series products are designed to provide excellent, natural color rendition with high efficiency. XIM Standard Series comes in 2700K, 3000K, 3500K and 4000K CCT, and in flux packages from 700 to 3000 lumens, delivering typical CRI (Ra) of 83, and consistently high R values across all 15 CIE CRI samples.

Xicato Corrected Cold Phosphor Portfolio (see also XCA)

Xicato Portfolio	Lumen Output	Correlated Color Temperature							
		2700K		3000K		3500k		4000K	
Artist Series® CIE CRI: Ra 95+, R9 90+ IES TM-30: Rf 96, Rg 103	700	⊙		⊙		⊙		⊙	
	1300	⊙	⊙	⊙	⊙	⊙	⊙	⊙	⊙
	2000	•	⊙	•	⊙	•	⊙	•	⊙
	3000		•		•		•		•
	4000		•		•		•		•
Beauty Series™ CIE CRI: Ra 95 IES TM-30: Rf 91, Rg 107	1300		⊙						
	2000		⊙						
Designer Series™ CIE CRI: Ra 90+, R9 50+ IES TM-30: Rf 88, Rg 101	700	⊙		⊙		⊙		⊙	
	1300	⊙	⊙	⊙	⊙	⊙	⊙	⊙	⊙
	2000	⊙	⊙	⊙	⊙	⊙	⊙	⊙	⊙
	3000		⊙		⊙		⊙		⊙
	4500				•		•		•
Standard Series CIE CRI: Ra 80+ IES TM-30: Rf 78, Rg 101	700	⊙		⊙		⊙		⊙	
	1300	⊙	⊙	⊙	⊙	⊙	⊙	⊙	⊙
	2000	⊙	⊙	⊙	⊙	⊙	⊙	⊙	⊙
	3000		⊙		⊙		⊙		⊙
	4000		•		•		•		•
	5000		•		•		•		•
Vibrant Series® V80 CIE CRI: Ra 80+ IES TM-30: Rf 73, Rg 105	700			⊙					
	1300			⊙	⊙				
	2000			⊙	⊙				
	3000				⊙				
	4000				•				
	5000				•				
Vibrant Series® V95 CIE CRI: Ra 95+ IES TM-30: Rf 93, Rg 106	700			⊙					
	1300			⊙	⊙				
	2000			•	⊙				
	3000				•				
	4000				•				

Note: CRI listed as XX+ are guaranteed minimum values.
 Typical values are min+3.

	XCA + XTM	+XIM
9mm LES	•	⊙
19mm LES	•	⊙

Ordering Guide

Part Numbering System

NOTE that all combinations are not available. Please see listing, below.

XIM	19	95	30	13	A2	A
XCA: Xicato Core Array XIM: Xicato Intelligent Module XTM: Xicato Thin Module	Light Emitting Surface (LES mm)	Series	CCT (K)	Flux (nominal)	Feature Group	Revision
	09:9	80: Standard	27: 2700	07:700	A2: DALI	
	19:19	90: Designer	30: 3000	13: 1300	A3: 1-10V	
		95: Artist	35: 3500	20: 2000	A5: BLE+DALI	
		BT: Beauty	40: 4000	etc.	A6: BLE+1-10V	
		V9: Vibrant 95	01: NA		CC: constant current	

Part Codes and Descriptions

XIM Standard Series with 9mm Light Emitting Surface (LES)

Part Number	Description
XIM09802707A2A	LED Module, XIM, LES09, Standard, 2700K, 700LM, DALI
XIM09802707A3A	LED Module, XIM, LES09, Standard, 2700K, 700LM, 1-10V
XIM09802707A5B	LED Module, XIM, LES09, Standard, 2700K, 700LM, DALI+BLE
XIM09802707A6B	LED Module, XIM, LES09, Standard, 2700K, 700LM, 1-10V+BLE
XIM09802713A2A	LED Module, XIM, LES09, Standard, 2700K, 1300LM, DALI
XIM09802713A3A	LED Module, XIM, LES09, Standard, 2700K, 1300LM, 1-10V
XIM09802713A5B	LED Module, XIM, LES09, Standard, 2700K, 1300LM, DALI+BLE
XIM09802713A6B	LED Module, XIM, LES09, Standard, 2700K, 1300LM, 1-10V+BLE
XIM09802720A2A	LED Module, XIM, LES09, Standard, 2700K, 2000LM, DALI
XIM09802720A3A	LED Module, XIM, LES09, Standard, 2700K, 2000LM, 1-10V
XIM09802720A5B	LED Module, XIM, LES09, Standard, 2700K, 2000LM, DALI+BLE
XIM09802720A6B	LED Module, XIM, LES09, Standard, 2700K, 2000LM, 1-10V+BLE
XIM09803007A2A	LED Module, XIM, LES09, Standard, 3000K, 700LM, DALI
XIM09803007A3A	LED Module, XIM, LES09, Standard, 3000K, 700LM, 1-10V
XIM09803007A5B	LED Module, XIM, LES09, Standard, 3000K, 700LM, DALI+BLE
XIM09803007A6B	LED Module, XIM, LES09, Standard, 3000K, 700LM, 1-10V+BLE
XIM09803013A2A	LED Module, XIM, LES09, Standard, 3000K, 1300LM, DALI
XIM09803013A3A	LED Module, XIM, LES09, Standard, 3000K, 1300LM, 1-10V
XIM09803013A5B	LED Module, XIM, LES09, Standard, 3000K, 1300LM, DALI+BLE

Suggested Cable Harness
 (one per unit, order separately)
XSA-331
 XIM 6-pin 600mm
 1-10V/DALI
 Wire Harness

XIM09803013A6B	LED Module, XIM, LES09, Standard, 3000K, 1300LM, 1-10V+BLE
XIM09803020A2A	LED Module, XIM, LES09, Standard, 3000K, 2000LM, DALI
XIM09803020A3A	LED Module, XIM, LES09, Standard, 3000K, 2000LM, 1-10V
XIM09803020A5B	LED Module, XIM, LES09, Standard, 3000K, 2000LM, DALI+BLE
XIM09803020A6B	LED Module, XIM, LES09, Standard, 3000K, 2000LM, 1-10V+BLE
XIM09803507A2A	LED Module, XIM, LES09, Standard, 3500K, 700LM, DALI
XIM09803507A3A	LED Module, XIM, LES09, Standard, 3500K, 700LM, 1-10V
XIM09803507A5B	LED Module, XIM, LES09, Standard, 3500K, 700LM, DALI+BLE
XIM09803507A6B	LED Module, XIM, LES09, Standard, 3500K, 700LM, 1-10V+BLE
XIM09803513A2A	LED Module, XIM, LES09, Standard, 3500K, 1300LM, DALI
XIM09803513A3A	LED Module, XIM, LES09, Standard, 3500K, 1300LM, 1-10V
XIM09803513A5B	LED Module, XIM, LES09, Standard, 3500K, 1300LM, DALI+BLE
XIM09803513A6B	LED Module, XIM, LES09, Standard, 3500K, 1300LM, 1-10V+BLE
XIM09803520A2A	LED Module, XIM, LES09, Standard, 3500K, 2000LM, DALI
XIM09803520A3A	LED Module, XIM, LES09, Standard, 3500K, 2000LM, 1-10V
XIM09803520A5B	LED Module, XIM, LES09, Standard, 3500K, 2000LM, DALI+BLE
XIM09803520A6B	LED Module, XIM, LES09, Standard, 3500K, 2000LM, 1-10V+BLE
XIM09804007A2A	LED Module, XIM, LES09, Standard, 4000K, 700LM, DALI
XIM09804007A3A	LED Module, XIM, LES09, Standard, 4000K, 700LM, 1-10V
XIM09804007A5B	LED Module, XIM, LES09, Standard, 4000K, 700LM, DALI+BLE
XIM09804007A6B	LED Module, XIM, LES09, Standard, 4000K, 700LM, 1-10V+BLE
XIM09804013A2A	LED Module, XIM, LES09, Standard, 4000K, 1300LM, DALI
XIM09804013A3A	LED Module, XIM, LES09, Standard, 4000K, 1300LM, 1-10V
XIM09804013A5B	LED Module, XIM, LES09, Standard, 4000K, 1300LM, DALI+BLE
XIM09804013A6B	LED Module, XIM, LES09, Standard, 4000K, 1300LM, 1-10V+BLE
XIM09804020A2A	LED Module, XIM, LES09, Standard, 4000K, 2000LM, DALI
XIM09804020A3A	LED Module, XIM, LES09, Standard, 4000K, 2000LM, 1-10V
XIM09804020A5B	LED Module, XIM, LES09, Standard, 4000K, 2000LM, DALI+BLE
XIM09804020A6B	LED Module, XIM, LES09, Standard, 4000K, 2000LM, 1-10V+BLE

Suggested Cable Harness
(one per unit, order separately)
XSA-331
XIM 6-pin 600mm
1-10V/DALI
Wire Harness

XIM Standard Series with 19mm Light Emitting Surface (LES)

Part Number	Description
XIM19802713A2A	LED Module, XIM, LES19, Standard, 2700K, 1300LM, DALI
XIM19802713A3A	LED Module, XIM, LES19, Standard, 2700K, 1300LM, 1-10V
XIM19802713A5B	LED Module, XIM, LES19, Standard, 2700K, 1300LM, DALI+BLE
XIM19802713A6B	LED Module, XIM, LES19, Standard, 2700K, 1300LM, 1-10V+BLE
XIM19802720A2A	LED Module, XIM, LES19, Standard, 2700K, 2000LM, DALI
XIM19802720A3A	LED Module, XIM, LES19, Standard, 2700K, 2000LM, 1-10V
XIM19802720A5B	LED Module, XIM, LES19, Standard, 2700K, 2000LM, DALI+BLE

XIM19802720A6B	LED Module, XIM, LES19, Standard, 2700K, 2000LM, 1-10V+BLE
XIM19802730A2A	LED Module, XIM, LES19, Standard, 2700K, 3000LM, DALI
XIM19802730A3A	LED Module, XIM, LES19, Standard, 2700K, 3000LM, 1-10V
XIM19802730A5B	LED Module, XIM, LES19, Standard, 2700K, 3000LM, DALI+BLE
XIM19802730A6B	LED Module, XIM, LES19, Standard, 2700K, 3000LM, 1-10V+BLE
XIM19803013A2A	LED Module, XIM, LES19, Standard, 3000K, 1300LM, DALI
XIM19803013A3A	LED Module, XIM, LES19, Standard, 3000K, 1300LM, 1-10V
XIM19803013A5B	LED Module, XIM, LES19, Standard, 3000K, 1300LM, DALI+BLE
XIM19803013A6B	LED Module, XIM, LES19, Standard, 3000K, 1300LM, 1-10V+BLE
XIM19803020A2A	LED Module, XIM, LES19, Standard, 3000K, 2000LM, DALI
XIM19803020A3A	LED Module, XIM, LES19, Standard, 3000K, 2000LM, 1-10V
XIM19803020A5B	LED Module, XIM, LES19, Standard, 3000K, 2000LM, DALI+BLE
XIM19803020A6B	LED Module, XIM, LES19, Standard, 3000K, 2000LM, 1-10V+BLE
XIM19803030A2A	LED Module, XIM, LES19, Standard, 3000K, 3000LM, DALI
XIM19803030A3A	LED Module, XIM, LES19, Standard, 3000K, 3000LM, 1-10V
XIM19803030A5B	LED Module, XIM, LES19, Standard, 3000K, 3000LM, DALI+BLE
XIM19803030A6B	LED Module, XIM, LES19, Standard, 3000K, 3000LM, 1-10V+BLE
XIM19803513A2A	LED Module, XIM, LES19, Standard, 3500K, 1300LM, DALI
XIM19803513A3A	LED Module, XIM, LES19, Standard, 3500K, 1300LM, 1-10V
XIM19803513A5B	LED Module, XIM, LES19, Standard, 3500K, 1300LM, DALI+BLE
XIM19803513A6B	LED Module, XIM, LES19, Standard, 3500K, 1300LM, 1-10V+BLE
XIM19803520A2A	LED Module, XIM, LES19, Standard, 3500K, 2000LM, DALI
XIM19803520A3A	LED Module, XIM, LES19, Standard, 3500K, 2000LM, 1-10V
XIM19803520A5B	LED Module, XIM, LES19, Standard, 3500K, 2000LM, DALI+BLE
XIM19803520A6B	LED Module, XIM, LES19, Standard, 3500K, 2000LM, 1-10V+BLE
XIM19803530A2A	LED Module, XIM, LES19, Standard, 3500K, 3000LM, DALI
XIM19803530A3A	LED Module, XIM, LES19, Standard, 3500K, 3000LM, 1-10V
XIM19803530A5B	LED Module, XIM, LES19, Standard, 3500K, 3000LM, DALI+BLE
XIM19803530A6B	LED Module, XIM, LES19, Standard, 3500K, 3000LM, 1-10V+BLE
XIM19804013A2A	LED Module, XIM, LES19, Standard, 4000K, 1300LM, DALI
XIM19804013A3A	LED Module, XIM, LES19, Standard, 4000K, 1300LM, 1-10V
XIM19804013A5B	LED Module, XIM, LES19, Standard, 4000K, 1300LM, DALI+BLE
XIM19804013A6B	LED Module, XIM, LES19, Standard, 4000K, 1300LM, 1-10V+BLE
XIM19804020A2A	LED Module, XIM, LES19, Standard, 4000K, 2000LM, DALI
XIM19804020A3A	LED Module, XIM, LES19, Standard, 4000K, 2000LM, 1-10V
XIM19804020A5B	LED Module, XIM, LES19, Standard, 4000K, 2000LM, DALI+BLE
XIM19804020A6B	LED Module, XIM, LES19, Standard, 4000K, 2000LM, 1-10V+BLE
XIM19804030A2A	LED Module, XIM, LES19, Standard, 4000K, 3000LM, DALI
XIM19804030A3A	LED Module, XIM, LES19, Standard, 4000K, 3000LM, 1-10V
XIM19804030A5B	LED Module, XIM, LES19, Standard, 4000K, 3000LM, DALI+BLE
XIM19804030A6B	LED Module, XIM, LES19, Standard, 4000K, 3000LM, 1-10V+BLE

Suggested Cable Harness
(one per unit, order separately)
XSA-331
XIM 6-pin 600mm
1-10V/DALI
Wire Harness

Mechanical Characteristics

Mechanical Specifications	
Dimensions	Ø 50mm x 20mm (1.97" x 0.78") * Xicato recommends an insertion space of Ø 52mm
Weight	48 grams (1.69 oz.)
Module Source Type	Corrected Cold Phosphor Technology®
Module Housing	Injection molded glass filled PBT
Light Emitting Surface options	Ø 9mm (0.35") Ø 19mm (0.75")
Interfaces: Electrical	6-Pin terminal. TE part # 353908-6P. Mating connector TE 353907-1. Pin-out: P1 power +, P2 power -, P3 open, P4 open, P5 control+, P6 control-. 600mm wire harness accessory available through Avnet (part #2829114-2), Xicato Part # XSA-331.
Interfaces: Mechanical	Recommended mounting screws: M3 x 0.5mm x 25mm with split lock washer.
Mounting Torque	Min: 0.36N-m (3.2in-lbs). Max: 0.43N-m (3.8in-lbs)
Interface: Thermal	Integrated thermal pad. A mating thermal interface (i.e. heatsink) surface flatness of ≤ 0.1 mm and center hole less than Ø12 mm is recommended in order to maintain thermal performance.
Maximum Case Temperature	90°C
Shipping (20 pc MOQ):	20 count box: 347mm x 230mm x 9mm (14" x 9" x 4"), 1.4 kg (3 lbs.) gross weight 100 count box: 533mm x 254mm x 153mm (21" x 10" x 6"), 3 kg (7 lbs.) gross weight
Storage Temperature	-40°C to +85°C
Ingress Protection	IP20



XIM 9mm



XIM 9mm top



XIM 19mm



XIM 19mm top

Mechanical Drawings

NOTE: XIM 19mm is identical except for the diameter of the light emitting surface (19mm vs. 9mm)

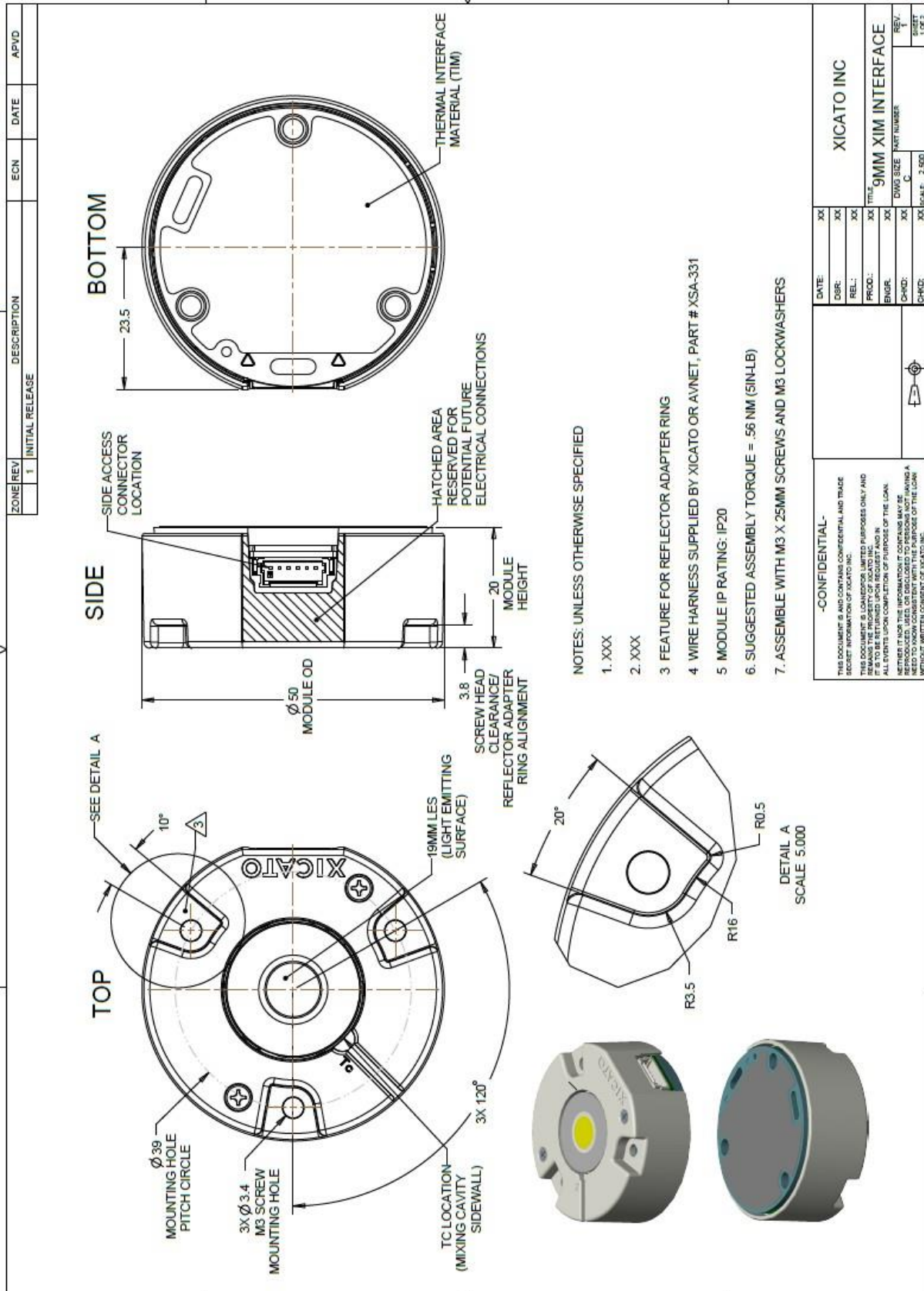

ZONE/REV	DESCRIPTION	ECN	DATE	APVD

**XIMCV SIDE ACCESS DETAIL
6 PIN MINI CT CONNECTOR**

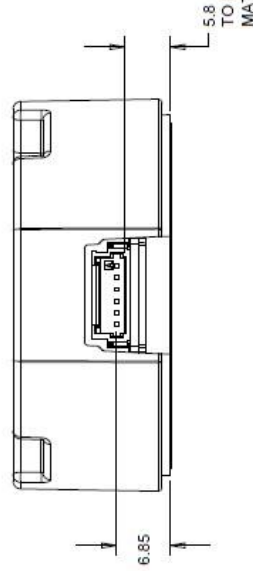
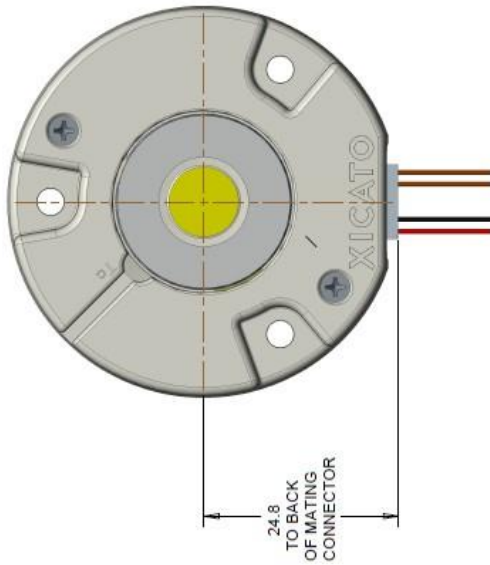

PIN#	WIRE COLOR	FUNCTION	AWG	RATING	LENGTH
1	RED	+ 48V POWER	24 (1.12 MM MAX INULATION OD)	1200mA	600 MM
2	BLACK	- 48V POWER	24 (1.12 MM MAX INULATION OD)	1200mA	600 MM
3	DNU	XICATO RESERVED	N/A	N/A	N/A
4	DNU	XICATO RESERVED	N/A	N/A	N/A
5	VIOLET	1-10V DIM + DALI CONTROL 1	24 (1.12 MM MAX INULATION OD)	50V 250mA	600 MM
6	GREY	1-10V DIM - DALI CONTROL 2	24 (1.12 MM MAX INULATION OD)	50V 250mA	600 MM

-CONFIDENTIAL-		DATE: XX	XX
THIS DOCUMENT IS AND CONTAINS CONFIDENTIAL AND TRADE SECRET INFORMATION OF XICATO INC.		DSR: XX	XX
THIS DOCUMENT IS LOANED FOR LIMITED PURPOSES ONLY AND REMAINS THE PROPERTY OF XICATO INC. IT IS TO BE RETURNED TO XICATO INC. UPON COMPLETION OF THE LOAN. ALL RIGHTS UPON COMPLETION OF PURPOSE OF THE LOAN. NEITHER IT NOR THE INFORMATION IT CONTAINS MAY BE REPRODUCED, USED, OR ENCLOSED TO PERSONS NOT HAVING A WRITTEN AUTHORIZATION FROM XICATO INC. WITHOUT WRITTEN CONSENT OF XICATO INC.		REL: XX	XX
		PROD: XX	XX
		ENGR: XX	XX
		CHND: XX	XX
		CHID: XX	XX
		DWG SIZE: 9MM XIM INTERFACE	REV. 2
		DWG NUMBER: C	ISS: 7/20/21
		SCALE: 2.500	

Electrical & Dimming Characteristics

Module Electronics Lifetime	5,400,000 hrs MTBF calculated @ 90°C, 0.6 CL, per Telcordia SR-332 Issue 3
Power in Off State (XIM Gen4)	DALI+BLE (A5B): 270mW, 1-10V+BLE (A6B): 380mW

Over Temperature Protection	
Fold Back Temperature	93°C (reduces to 85% of set level)
Shut-off Temperature	98°C
Restore Temperature	85°C (increases back to 100% of set level)

Dimming Information: All Protocols	
Dim to Off (0%)	Yes
On/off threshold	≤ 0.05% of module maximum rated intensity. Subject to change.

Dimming Information: Bluetooth Smart	
Dimming Profile	Logarithmic (default) or linear, configurable
Minimum Dim Setting	0.1% of maximum intensity
Dimming Granularity	0.01% resolution (10,000 steps from 100% to 0.01%)

Dimming Information: DALI (IEC 62386-101/102:2009 and IEC 62386-207)	
Dimming Profile	Logarithmic (default) or linear, configurable
Minimum Dim Setting	0.1% of maximum intensity
Dimming Granularity	255 steps
Dimming Compatibility	DALI 1.0. Additional compatibility information available at www.xicato.com

Dimming Information: 1-10V / 0-10V (IEC 60929 ANNEX E)		
Dimming Profile	< 0.5V	0% (off) (> 0.75V to turn back on)
	≥ 0.5V and < 1.0V	1%
	≥ 1.0V and < 9.0V	$12.375\% \times (V_{1-10V} - 1) + 1\%$
	≥ 9.0V	100%
Dimming Compatibility	XIM is compatible with a wide range of 1-10V sink dimming systems. Refer to dimming compatibility documentation at www.xicato.com .	
Potentiometer Compatibility	100kOhm typical	

Dimming and Flicker			
Reference	Luminous Intensity	Modulation Frequency	Risk Level
Reference IEEE Std 1789-2015: "IEEE Recommended Practices for Modulating Current in High-Brightness LEDs for Mitigating Health Risks to Viewers"	100% - 1.25% of max	≥ 3,000 Hz	No Effect
	1.25% - 0.5% of max	≥ 1,250 Hz	Low Risk
	0.5% - 0.1% of max	> 1,250 Hz	Medium Risk

Wireless Specifications & Compliance

Protocol	Bluetooth 5.1
Spectral band	2.4 GHz
Bandwidth	1 Mbps
Channels	40
Transmission Power	-18 dBm to +8 dBm
Receive Sensitivity	-96 dBm @ 1Mb/s
RSSI Resolution	1 dB resolution
Signal to Noise Ratio (SNR)	> 5:1

UNITED STATES

FCC Notice: This device complies with Part 15 of the FCC Rules. The device meets the requirements for the modular transmitter approval as detailed in FCC public Notice DA00-1407. Transmitter Operation is subject to the following two conditions: (1) This device may not cause harmful interference, and (2) This device must accept any interference received, including interference that may cause undesired operation.

Note: This equipment has been tested and found to comply with the limits for a Class B digital device, pursuant to Part 15 of the FCC Rules. These limits are designed to provide reasonable protection against harmful interference in a residential installation. This equipment generates and can radiate radio frequency energy and, if not installed and used in accordance with the instructions, may cause harmful interference to radio communications. However, there is no guarantee that interference will not occur in a particular installation. If this equipment does cause harmful interference to radio or television reception, which can be determined by turning the equipment off and on, the user is encouraged to try to correct the interference by one or more of the following measures:

- Reorient or relocate the receiving antenna.
- Increase the separation between the equipment and receiver.
- Connect the equipment into an outlet on a circuit different from that to which the receiver is connected.
- Consult the dealer or an experienced radio/TV technician for help

Labeling Requirements: The Original Equipment Manufacturer (OEM) must ensure that FCC labelling requirements are met. This includes a clearly visible label on the outside of the OEM enclosure specifying the appropriate FCC identifier for this product as well as the FCC Notice above. The FCC identifier is FCC ID: X8WBC833M. In any case the end product must be labeled on the exterior with "FCC ID: X8WBC833M".

CANADA

ISED Notice: The device complies with Canada RSS-GEN Rules. The device meets the requirements for modular transmitter approval as detailed in RSS-GEN. Operation is subject to the following two conditions: (1) This device may not cause harmful interference, and (2) This device must accept any interference received, including interference that may cause undesired operation.

L'appareil est conforme aux Règles RSS-GEN de Canada. L'appareil répond aux exigences d'approbation de l'émetteur modulaire tel que décrit dans RSS-GEN. L'opération est soumise aux deux conditions suivantes: (1) Cet appareil ne doit pas causer d'interférences nuisibles, et (2) Cet appareil doit accepter toute interférence reçue, y compris les interférences pouvant entraîner un fonctionnement indésirable.

ISED Interference Statement for Canada

This device complies with Innovation, Science and Economic Development (ISED) Canada licence-exempt RSS standard(s). Operation is subject to the following two conditions: (1) this device may not cause interference, and (2) this device must accept any interference, including interference that may cause undesired operation of the device.

Cet appareil est conforme à la norme sur l'innovation, la science et le développement économique (ISED) norme RSS exempte de licence. L'exploitation est autorisée aux deux conditions suivantes : (1) l'appareil ne doit pas produire de brouillage, et (2) l'utilisateur de l'appareil doit accepter tout brouillage radioélectrique subi, même si le brouillage est susceptible d'en compromettre le fonctionnement.

ISED Radiation Exposure Statement for Canada

This equipment complies with ISED radiation exposure limits set forth for an uncontrolled environment.

Cet équipement est conforme aux limites d'exposition aux radiations ISED prévues pour un environnement incontrôlé.

Labeling Requirements

The Original Equipment Manufacturer (OEM) must ensure that ISED labelling requirements are met. This includes a clearly visible label on the outside of the OEM enclosure specifying the appropriate IC identifier for this product as well as the ISED Notice above. The IC identifier is 4100A-BC833M. In any case, the end product must be labeled in its exterior with "IC: 4100A-BC833M".

Europe

Declaration of Conformity: Hereby, Xicato declares that the XIM series products comply with the essential requirements and other relevant provisions of RED 2014/53/EU.

Japan

MIC Japan certificate R 218-417364

Software & Firmware Features

Protocol Security	AES-128 (128-bit encryption)
Site Scalability	Over 140 trillion individually addressable nodes per site (2^{37})
	4,294,967,296 secure networks per site (2^{32}). Secure networks CANNOT overlap.
	32,767 nodes per secure network ($2^{15} - 1$). One secure network per node.
	16,383 groups per secure network ($2^{14} - 1$). Groups can overlap.
XIM scalability	65,535 scenes per secure network ($2^{16} - 1$). Scenes can overlap.
	Each XIM can be a member of one secure network at a time.
	Each XIM can be a member of up to 16 groups at one time. Groups can overlap.
	Each XIM can participate in up to 32 scenes at one time. Scenes can overlap.

Internal Sensor Data Collection & Storage

Real-time reporting	Current Intensity level
	Current Temperature of LED core (Tc)
	Current Temperature of electronics printed circuit board (PCB).
	Current Input power, voltage and ripple current
	Current Group membership (provisioned)
	Current Scene membership (provisioned)
Stored operating history	Total operating hours (time at > 0% intensity)
	Power cycles (power on/off)
	LED cycles (LEDs turned on/off, unit still powered)
	Histogram representing time spent in operating parameter range: temperature, intensity
Stored module Information	Module part number
	GTIN
	Serial number
	XIM hardware revision
	XIM firmware revision
	Bluetooth firmware revision
	Maximum flux
	Programmed flux
	LES (light emitting surface diameter)
	CCT
	CRI
Enabled dimming protocol(s)	
Stored OEM programming	OEM serial number (12 bytes)
	36 bytes optional free text data

Warranty

Warranty Duration	Verifiable 10 years or 50,000 hours of operation at luminous intensity > 0%. Verification based on actual operating data stored in each module.
Warranty coverage	Covers initial color consistency, lumen maintenance, color maintenance, and drive electronics on EVERY module (B0). No failures.
Initial Color Consistency	Every light source is within 1x2 MacAdam Ellipse (1x2 SDCM) of target color point. Flux and color point tuned at case temperature 70°C.
Lumen Maintenance	Better than 70% (L70, B0, F0) at 50,000 hours at maximum operating drive current and maximum case temperature (90°C).
Color Maintenance	Luminaires within a contiguous space shall remain within $\pm 0.003 \Delta u'v'$ of each other at maximum case temperature (90°C) for the duration of the warranty.
Full warranty text at	www.xicato.com/support/warranty

Color Specifications

Initial Color Consistency – Details

Notes:

1. Artist Series and Standard Series color point targets are on the Planckian locus at each specified CCT
2. Vibrant Series color point target is -0.003 Duv
3. Beauty Series color point target is -0.006 Duv
4. All metrics are calculated according to the proprietary Xicato color matching function

Correlated Color Temp			Initial Color Consistency	
Nominal	Actual	CCT	Duv	SDCM
2700K	2700K	± 40K	± 0.001	± 1x2
3000K	2950K	± 50K		
3500K	3420K	± 60K		
4000K	4000K	± 70K		

Color Metrics: Standard Series

Optimized for excellent, natural color rendition with high efficiency.

All color rendering data at highest rated drive current and 70°C case temperature (Tc).
 Tester consistency (reproducibility) ± 0.0002 Duv (CIE 1964) from NIST reference

Correlated Color Temperature	2700K, 3000K, 3500K, or 4000K nominal 3000K used as test reference.
Initial Color Consistency	≤ 1x2 Macadam ellipses (SDCM) at 70°C, B0
CIE CRI Minimums	R _a ≥ 80, R9 ≥ 90
Color Maintenance	Consistency maintained < 0.003 Δu'v' at 50,000 hours
Lumen Maintenance	L70/B0 at 50,000 hours
Warranty	Verifiable 10 years or 50,000 hours for individual modules (B0) on mortality, color and lumen maintenance (XIM only). Details at www.xicato.com/support/warranty

CIE CRI Color Metrics (values are typical)

	R _a	R1	R2	R3	R4	R5	R6	R7	R8	R9	R10	R11	R12	R13	R14	R15	GAI _{BB}
Standard Series	83	80	88	95	81	80	85	85	63	14	73	80	70	81	97	74	96

Spectral Power Distribution vs. Reference Source

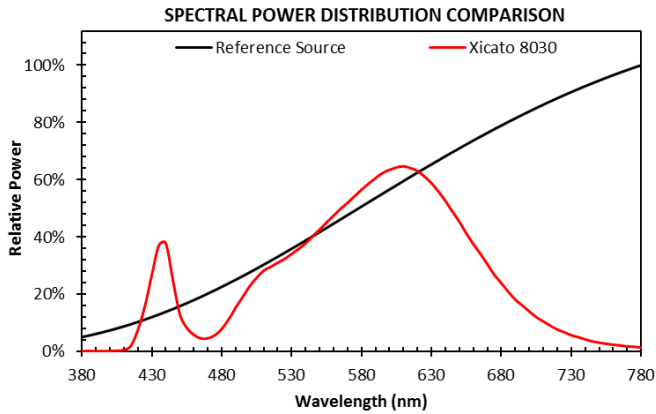

CIE Color Gamut

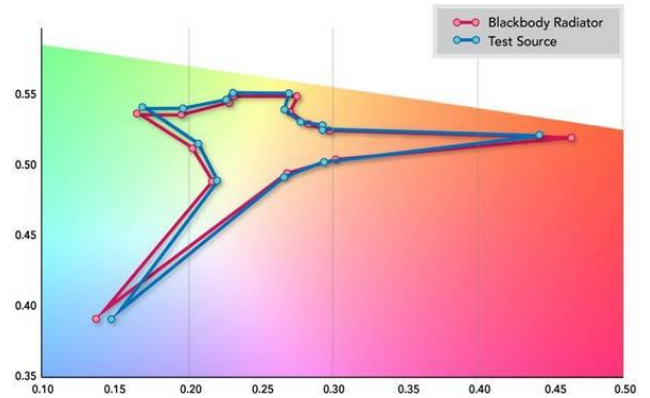

Color Consistency

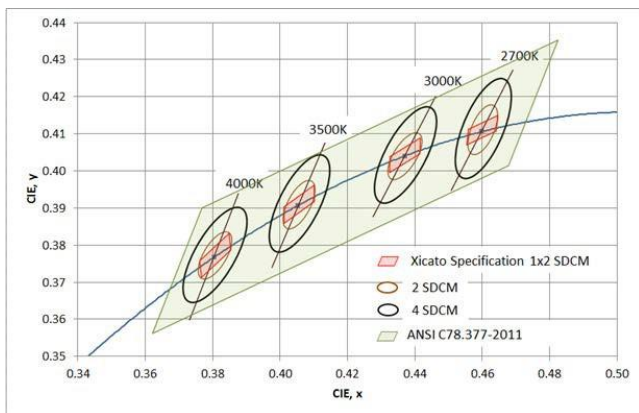

Color Maintenance

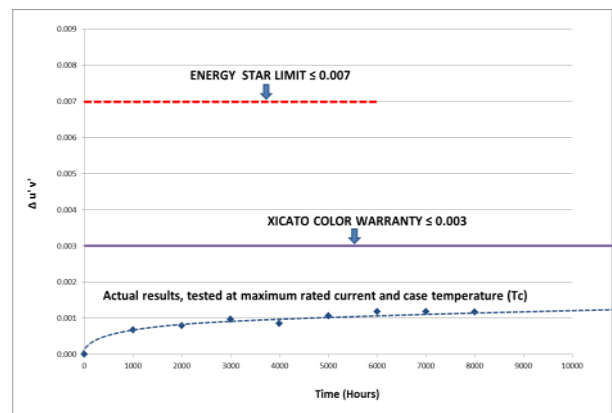

IES TM-30 Color Metrics

(Values are typical. Based on 3000K CCT)

IES TM-30 Color Fidelity (R_f) 78
 IES TM-30 Color Gamut (R_g) 101

CES Chromaticity Comparison

This plot shows the shift in chromaticity for each individual color evaluation sample (CES). Closer proximity between paired dots indicates higher fidelity.

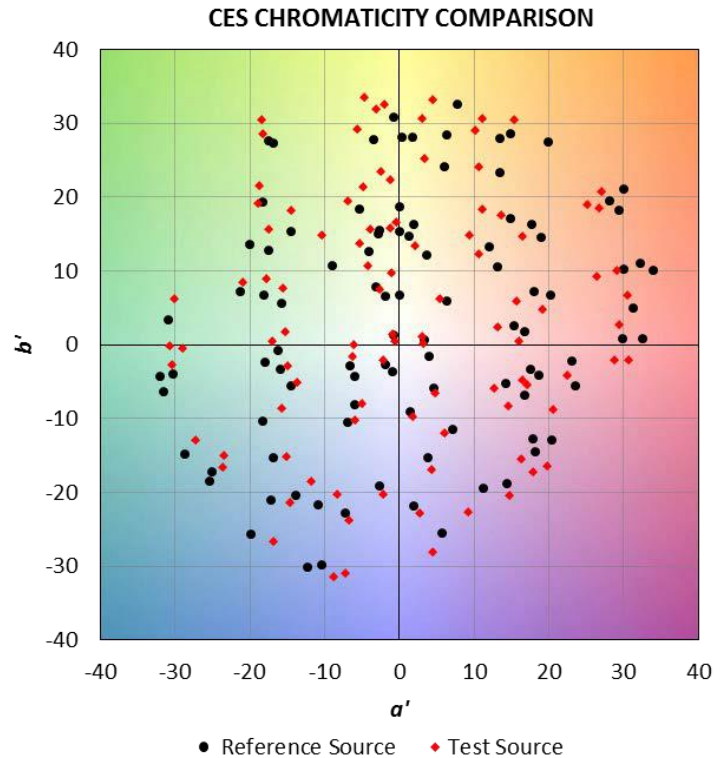

Color Vector Graphic

This plot shows the average chromaticity shift for the samples within each of 16 hue bins, which are compiled out of the 99 IES TM-30 Color Evaluation Samples. The values are normalized so that the reference is a circle.

Vector arrows indicate the direction and degree of the shift for each hue bin.

- Radial shift indicates an increase/decrease in saturation.
- Tangential shift indicates a shift in hue.
- Length of arrow indicates degree of shift.

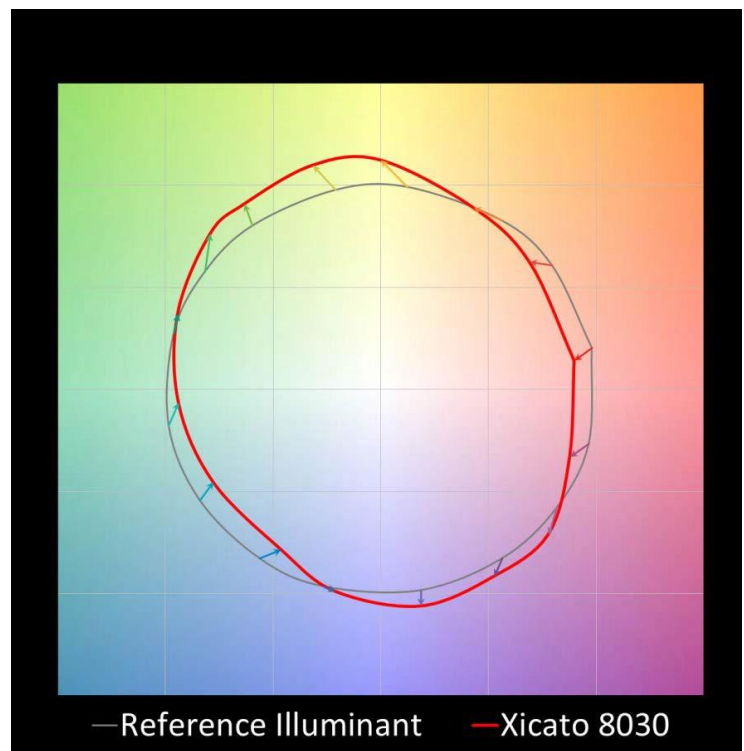

IES LM-80

Standard Series 19MM, 3000K, 3000 Lumens

Testing conducted at BACL. $T_c = 90^\circ\text{C}$, $I_f = 1050\text{mA}$, HTOL, 8000 Hrs.

Lumen Maintenance

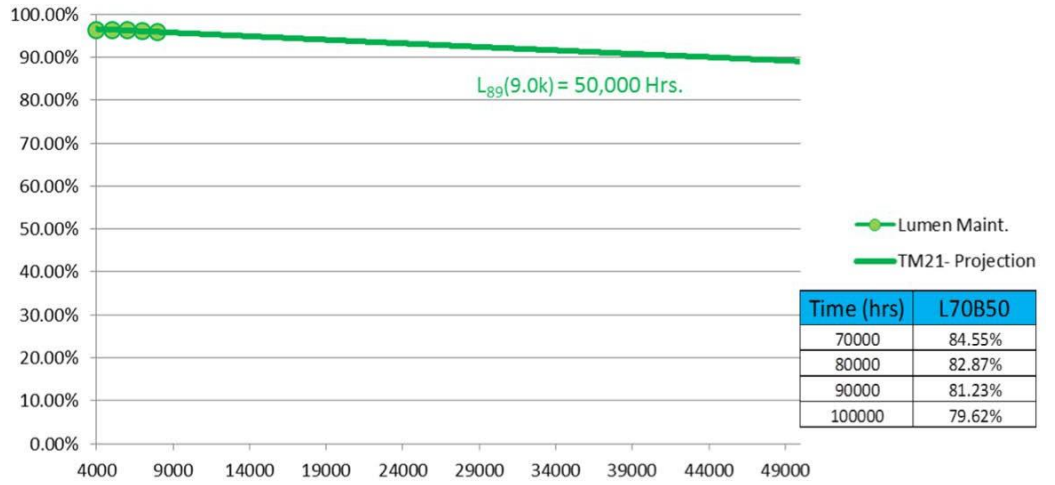

Color Maintenance

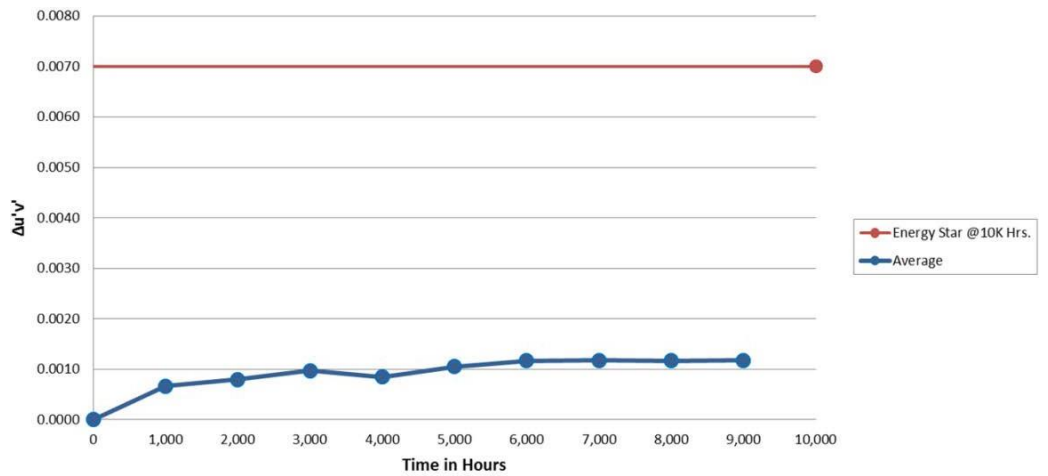

Color Maintenance (Normalized)

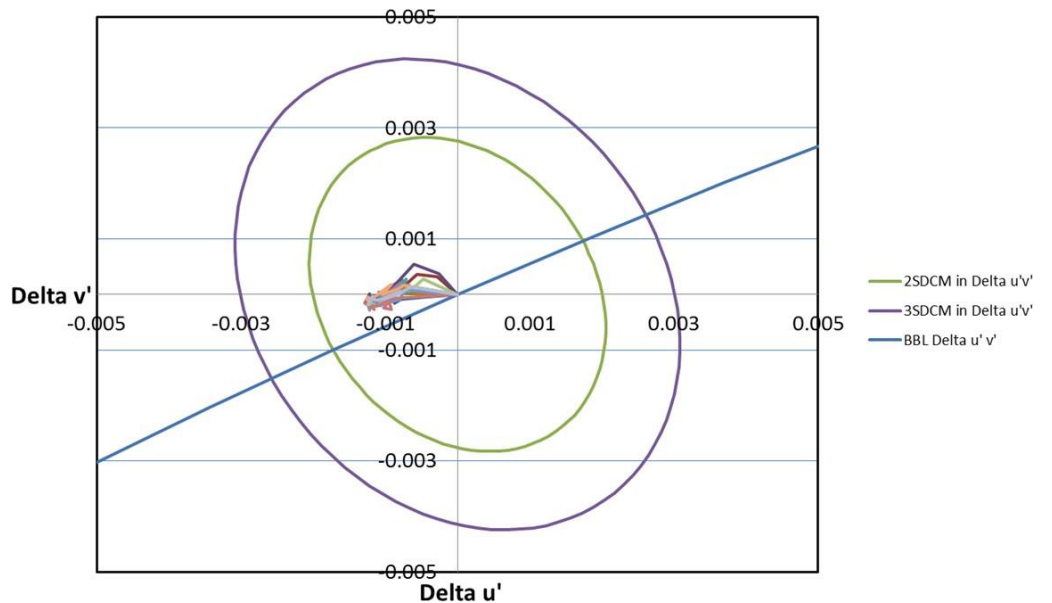

Standard Series, 19MM, 3000K, 5000 Lumens

Testing conducted at BACL. $T_c = 90^\circ\text{C}$, $I_f = 1400\text{mA}$, HTOL, 6000 Hrs.

Lumen Maintenance

Lumen Maintenance
Qty. 13 BACL 8030-5000
at $T_c = 90^\circ\text{C}$, $I_f = 1400\text{mA}$, HTOL, 6000 Hrs.

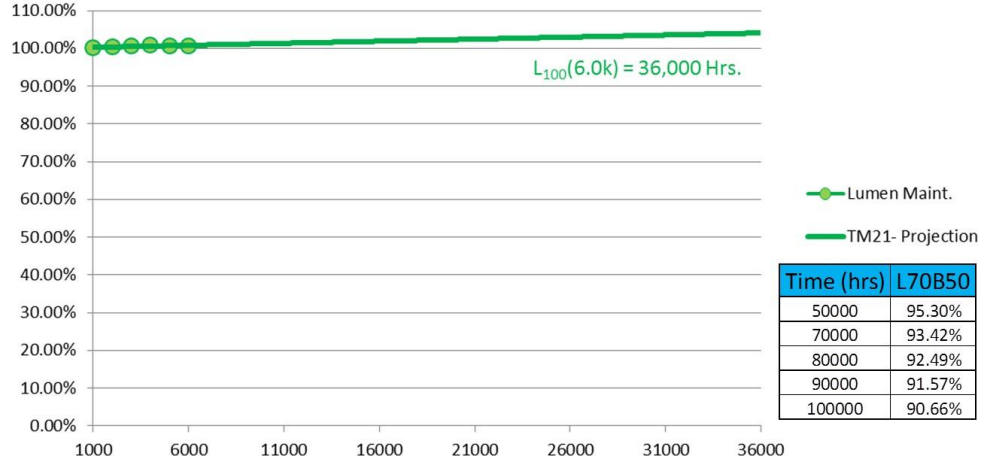

Color Maintenance

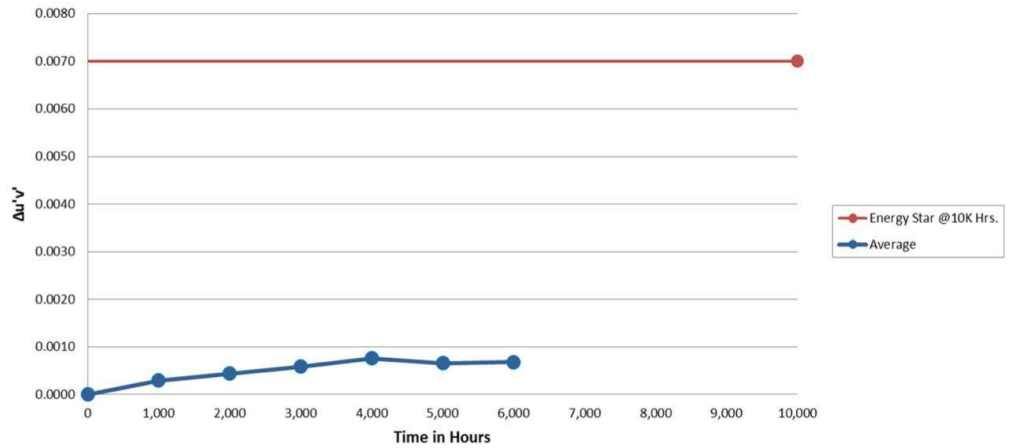

Color Maintenance (Normalized)

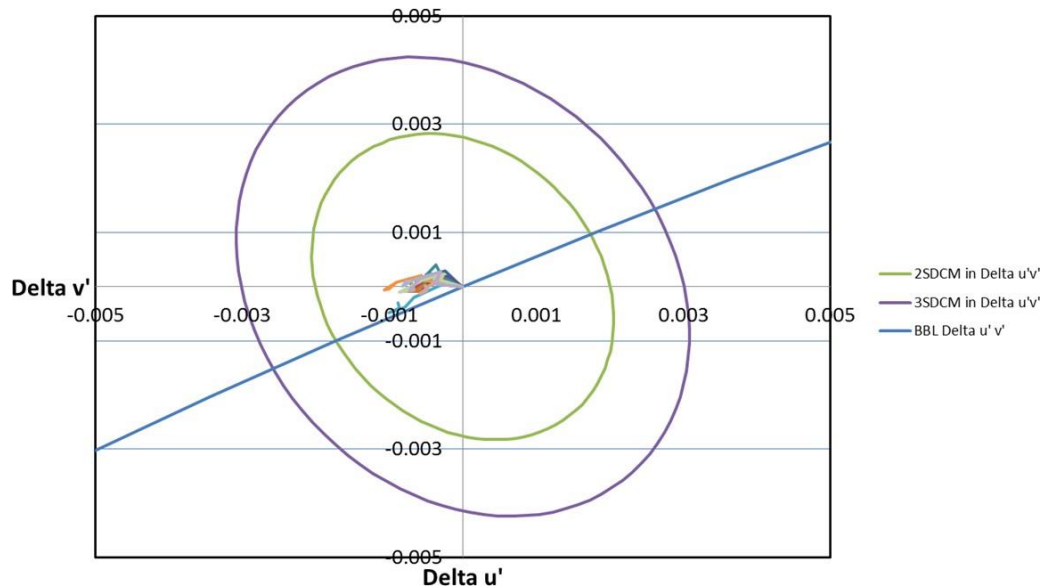

Performance Characteristics

More extensive performance data is available from your Xicato sales representative.

Notes:

1. Absolute range of lumen output is $\pm 10\%$ of typical value.
2. Specifications are subject to change without notice.

Absolute Maximum Ratings

Supply Input Voltage (V_{in+})	56V DC, referenced to V_{in-}
(0-10V) DIM+	20V DC, referenced to DIM- (V_{in-} is directly connected to DIM- in the XIM)
Tc	90°C

Recommended Operating Conditions

	Min	Typical	Max
Input Voltage	45.6	48	50.4
Turn on Voltage		40	
Turn off Voltage		38	
Shutdown Voltage		30	

Power Supply Requirements

Listed below are the power consumption ratings of the XIM. These ratings should be used to determine the minimum rating of the power supply (PSU) used to power the XIM.

Maximum Power (W)

The PSU power rating must meet or exceed the Max Power rating of the XIM selected. If multiple XIM are powered by a single PSU, then the power rating of the PSU must meet or exceed the sum of the Max Power ratings of all of the XIM being driven, combined.

Part Family	Max W
XIM0980xx07AxA, XIM0980xx07AxB	10.1
XIM0980xx13AxA, XIM0980xx13AxB	18.8
XIM0980xx20AxA, XIM0980xx20AxB	35.3
XIM1980xx13AxA, XIM1980xx13AxB	12.6
XIM1980xx20AxA, XIM1980xx20AxB	19.1
XIM1980xx30AxA, XIM1980xx30AxB	31.3

Power and Efficacy vs. Intensity

Note that the XIM with Bluetooth consumes a small amount of power due to its periodic wireless transmissions of operating data. Power shown at 0% is worst-case, based on full power and high frequency transmission, which is configurable.

Power in W Efficacy in lm/W	100%	75%	50%	24%	10%	5%	1%	0%
XIM0980xx07A5B	9.5	6.9	4.5	2.4	1.1	0.69	0.35	0.27
Efficacy (typ)	73	76	77	73	64	51	20	NA
XIM0980xx07A6B	9.6	7.0	4.7	2.5	1.2	0.80	0.46	0.38
Efficacy (typ)	73	75	75	70	58	44	15	NA
XIM0980xx13A5B	17.8	12.7	8.2	4.2	1.8	1.05	0.43	0.27
Efficacy (typ)	73	77	79	78	72	62	30	NA
XIM0980xx13A6B	17.9	12.9	8.3	4.3	1.9	1.2	0.54	0.38
Efficacy (typ)	72	76	78	76	68	56	24	NA
XIM0980xx20A5B	33.6	22.9	14.1	6.8	2.9	1.6	0.54	0.27
Efficacy (typ)	59	66	71	74	70	64	37	NA
XIM0980xx20A6B	33.8	23.0	14.3	6.9	3.0	1.7	0.65	0.38
Efficacy (typ)	59	65	70	72	67	60	31	NA
XIM1980xx13A5B	11.9	8.6	5.7	3.0	1.3	0.81	0.38	0.27
Efficacy (typ)	110	113	115	109	97	81	34	NA
XIM1980xx13A6B	12.0	8.7	5.8	3.1	1.5	0.92	0.49	0.38
Efficacy (typ)	108	112	112	105	89	71	27	NA
XIM1980xx20A5B	18.1	13.0	8.5	4.3	1.9	1.1	0.43	0.27
Efficacy (typ)	111	115	118	115	107	93	46	NA
XIM1980xx20A6B	18.2	13.1	8.6	4.5	2.0	1.2	0.54	0.38
Efficacy (typ)	110	114	117	112	101	85	37	NA
XIM1980xx30A5B	18.2	13.1	8.6	4.5	2.0	1.2	0.54	0.38
Efficacy (typ)	110	114	117	112	101	85	37	NA
XIM1980xx30A6B	29.9	21.2	13.6	6.9	3.0	1.7	0.64	0.38
Efficacy (typ)	100	106	111	109	101	90	47	NA

Performance Graphs

The latest graphs of XIM flux, CCT, and efficacy performance at different intensity and case temperature levels are available on Xicato website under Support / Documents and Tools.

1. In the “Choose a category” pull down menu, select “datasheets”.
2. In the “Choose a product” pull down menu, select “XIM Generation 4”.

Basic Handling and Assembly

General Handling

Make sure your **hands and tools are clean** before handling module.

Do not drop module or allow modules to rattle in a loosely packed container. This may dislodge internal electrical components, or scratch the phosphor or thermal interface pad.

Do not touch the phosphor coating on top of the LED array (the light emitting surface) **or the integrated thermal pad** underneath. These surfaces are sensitive to scratches, contamination, and debris which may decrease module performance. If any dust or debris accumulates on either surface, clean the surface by blowing on it with clean air. The phosphor surface can also be cleaned by gently wiping with isopropyl alcohol.

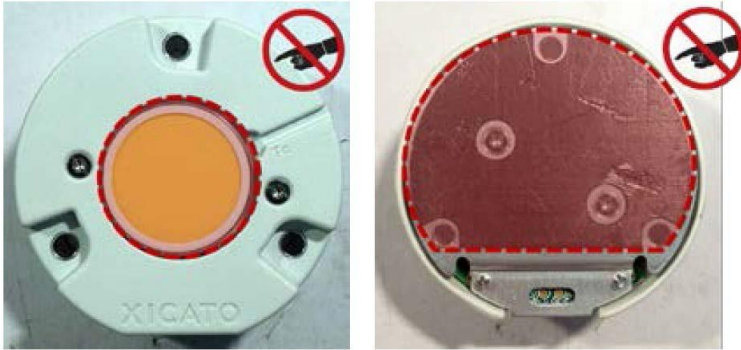

Do not touch sensitive surfaces. Keep them clean.

Assembly

Always use recommended screws and fasteners, and apply recommended torque. Take caution not to exceed these values as this may damage the module. Xicato recommends using a spring lock washer with either a flat washer or adapter ring at all mounting locations to reduce the likelihood that the fasteners will loosen under shock, vibration, or thermal cycling.

Be sure not to reverse polarity on the electrical leads to the module, as this may damage the module. Be absolutely certain to use the proper wire gauge and color and, when required, poke them into the proper connector. One-time poke-in connectors are not guaranteed to function properly if wires are pulled loose and reinserted.

Make sure that surfaces of thermal interface pad and heat sink are clean and free of debris before assembly. Visually verify that there are no gaps between thermal surfaces, and that pressure has been evenly applied across the entire surface.

Please note that Xicato is the only authorized distributor and supplier of twist-lock adaptor rings. For more information on adapter ring options, contact your XICATO account manager or technical representative.

For more detailed handling and assembly instructions, including:

- How to mount reflectors, adapters, fasteners
 - How to mount unit to heat sinks
 - Wiring and wire harness
 - How to test the module for thermal performance
- ...and more, please see "Application Note - XIM Assembly Instructions" on the Xicato website.

Regulatory Information

Drive Current

The product is designed for use with a constant voltage power supply. Refer to the Performance Characteristics section for details on operating voltage and current requirements.

Electrical Safety & Handling

CE	IEC 62031:2008 + A1:2012
UL	8750 recognized. Class 2. Suitable for dry and damp locations.
Ingress Protection rating:	IP20
CSA	C22.2 No. 250.13-12.

ESD Class 3B (HBM). No special ESD handling procedures required.

Eye Safety

The product is tested in accordance with IEC TR 62778.

For Blue Light it is rated for Risk Group 1.

Chemical Safety

The following chemicals should be avoided, even in small quantities, within the module:

Hydrochloric Acid	MEK (Methyl Ethyl Ketone)	Dichloromethane
Sulfuric Acid	MIBK (Methyl Isobutyl Ketone)	Rosin Flux Solder
Nitric Acid	Toluene	Castor Oil
Acetic Acid	Xylene	Lard Oil
Sodium Hydroxide	Benzene	Linseed Oil
Potassium Hydroxide	Gasoline	Petroleum Oil
Ammonia	Mineral Spirits	Silicone Oil
Sulfur (Used in Rubber Processing)	Tetrachloromethane (Carbon tetrachloride – CCl ₄)	Halogenated Hydrocarbons (Containing F, Cl, or Br)

Environmental Safety

RoHS compliant

Lead content: None

Mercury content: None

UV or IRC Emissions: None

Wireless Compliance

See Wireless Specifications

Energy Labeling & Single Lighting Regulations (ELR/SLR)

The XIM is considered to be a “containing product” as defined by Regulations (EU) 2019/2020 and (EU) 2019/2015.

Definition of “Containing Product”

Containing product means a product containing one or more light sources, or separate control gears, or both. Examples include luminaires that can be taken apart to allow separate verification of the contained light source(s), household appliances containing light source(s), furniture (shelves, mirrors, display cabinets) containing light source(s). If a containing product cannot be taken apart for verification of the light source and separate control gear, the entire containing product is to be considered a light source.

Conditions Met by XIM

Containing product means a product containing one or more light sources, or separate control gears, or both. Examples include luminaires that can be taken apart to allow separate verification of the contained light source(s), household appliances containing light source(s), furniture (shelves, mirrors, display cabinets) containing light source(s). If a containing product cannot be taken apart for verification of the light source and separate control gear, the entire containing product is to be considered a light source.

In case of the XIM modules, the removal and verification of the contained light source XCA with the use of commonly available tools, without permanent damage to the XCA, XIM or light fixture is possible. XIM can be dismantled from the installation environment for verification by market surveillance authorities and trained lighting professionals. The contained light source XCA can also be replaced at the Xicato factory by a similar unit for full electrical/mechanical/thermal/optical functionality. The control protocol specific driver is part of the XIM and the driver characteristics are in alignment with SLR. Instructions for disassembly and replacement are provided for XIM.

XIM also meets the requirements for dismantling of light sources from containing products at end of life.

XIM with the integrated control gear and separable light source must be disposed of at certified disposal companies in accordance with Directive 2012/19/EU (WEEE) in the EU and with Waste Electrical and Electronic Equipment (WEEE) Regulations 2013 in the UK. For this purpose, collection points for recycling centres and take-back systems (CRSO) are available from retailers or private disposal companies, which accept separate control gear and light sources free of charge. XIM products are RoHS compliant and should be disposed through such a system.

As stated in Annex I to Directive 2009/125/EC, item 28, containing products do not have to report the parameters mandated for a light source in the EPREL database and therefore data from nominal test conditions, as reported by light source manufacturer is sufficient for such products. This applies to XIM and performance data at nominal operating conditions is available in the product datasheets. In addition, the XCAs are in the process of being listed in the EPREL database and the light source attributes of the XCA will apply to the corresponding XIM model.

Additionally, as in Annex II to Directive 2009/125/EC, item 3b, a containing product does not require to display energy labels. Therefore, XIM products have not been assigned any energy labels.

Summary

XIM is both a control gear and a light source. The light source is the XCA and the XCA are removable for verification without damaging the XIM, using commonly available tools. Factory replacement with similar XCA units is also feasible. Therefore, as Containing Products, the XIM is not required to meet the energy labeling requirements or be registered in the EPREL database.

This information is also provided on www.xicato.com.

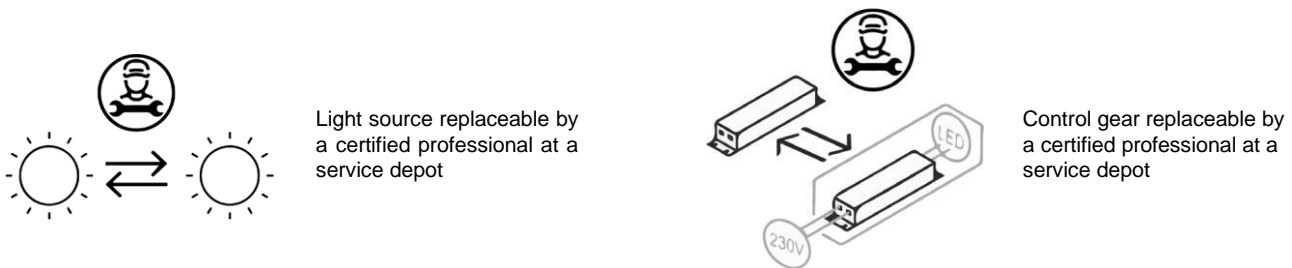

This product contains a light source of energy efficiency class as assigned to the corresponding model of the XCA light source aka containing product. The entire searchable list of XCA part numbers registered on the EPREL database is available at Xicato website under Resources >> Compliance & Regulatory

Disassembly Drawing

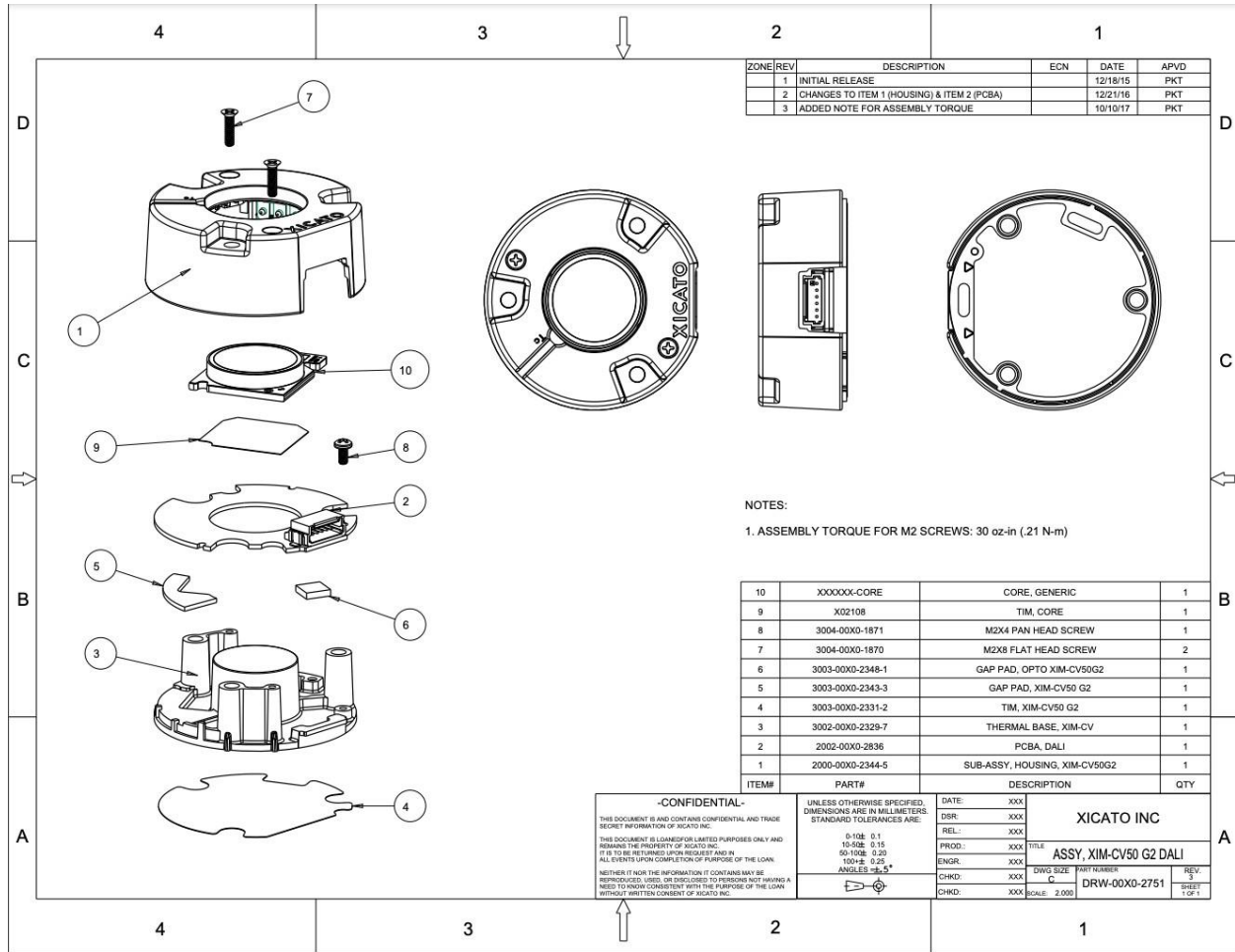

Note: For XIM disassembly & XCA verification: Remove screws (7), pop out XCA from housing
 For XCA replacement: Contact factory

Warranty

Warranty Duration	Verifiable 10 years or 50,000 hours of operation at luminous intensity > 0%. Verification based on actual operating data stored in each module.
Warranty coverage	Covers initial color consistency, lumen maintenance, color maintenance, and drive electronics on EVERY module (B0). No failures.
Initial Color Consistency	Every light source is within 1x2 MacAdam Ellipse (1x2 SDCM) of target color point. Flux and color point tuned at case temperature 70°C.
Lumen Maintenance	Better than 70% (L70, B0, F0) at 50,000 hours at maximum operating drive current and maximum case temperature (90°C).
Color Maintenance	Luminaires within a contiguous space shall remain within $\pm 0.003 \Delta u'v'$ of each other at maximum case temperature (90°C) for the duration of the warranty.
Full warranty text at	www.xicato.com/support/warranty

Luminaire Specification: Recommended LED Module

General Description

Color Rendering Index shall be ≥ 80 , with a typical value of 83.

Initial Color Consistency	Every light source shall be within a 1x2 MacAdam Ellipse (1x2 SDCM) Flux and color point tuned at case temperature 70°C
Initial Color Point Accuracy	Shall be within ± 0.001 Duv of Black Body Locus (BBL)
Color Maintenance	Luminaires within a contiguous space shall remain within 3 MacAdam Ellipses of each other at 50,000 hours at maximum operating drive current and maximum case temperature (90°C) LM-80 data at maximum rated current and 90°C shall show $\Delta u'v' < 0.003$ at 6,000 hours.
Lumen Maintenance	Shall be better than 70% (L70, B0, F0) at 50,000 hours at maximum operating drive current and maximum case temperature (90°C). LM-80 data at maximum rated current and 90°C shall show LM > 94.8% at 6,000 hours.
Phosphor Technology	Corrected Cold Phosphor Technology®
Dimming	Luminaire shall be capable of dimming to 1% or less of maximum intensity. Modulation and frequency for luminaire at 2% of maximum intensity shall fall within the No Effect area, and at 1% within the Low Risk area, of IEEE Std 1789-2015 (IEEE Recommended Practices for Modulating Current in High-Brightness LEDs for Mitigating Health Risks to Viewers).
Warranty	Verifiable 7 years or 50,000 hours, including minimum on mortality, lumen maintenance, and color maintenance. Mortality: B0 – No failures. Lumen maintenance: L70, B0 (better than 70% on <u>all</u> units). Color maintenance: $< 0.003 \Delta u'v'$ at 50,000 hours

Detailed Color Specifications

IES TM-30-15 Color rendering fidelity (R_f) shall be 78.

IES TM-30-15 Color rendering gamut (R_g) shall be 101.

Minimum CIE CRI (R_a) shall be 80; minimum R9 shall be 0.

Typical CIE CRI R values shall be:

R1:	80	R9:	14
R2:	88	R10:	73
R3:	95	R11:	80
R4:	81	R12:	70
R5:	80	R13:	81
R6:	85	R14:	97
R7:	85	R15:	14
R8:	63		

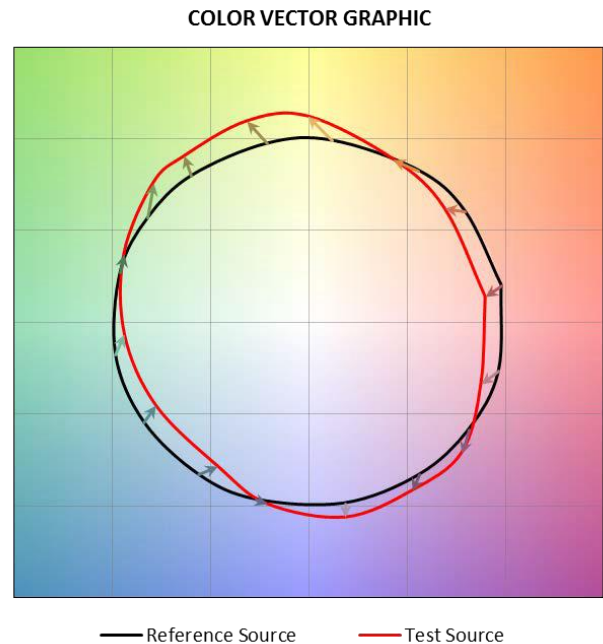

Typical CIE CRI Gamut Area Index GAI_{BB} shall be 96.

LED module shall be Xicato Intelligent Module (XIM), Standard Series: XIM0980****A*A, XIM0980****A*B, XIM1980****A*A, XIM1980****A*B or equivalent.



Xicato Global Headquarters

102 Cooper Court,
Los Gatos, CA 95032

Contact Us

Tel: +1 408 461 5575
info@xicato.com

For the most up-to-date data sheet, please visit xicato.com/support.

SBC Xicato Corporation product specifications are subject to change without notice. Xicato and the Xicato stylized logo design are registered trademarks of Xicato.